

1

2

3

4

A

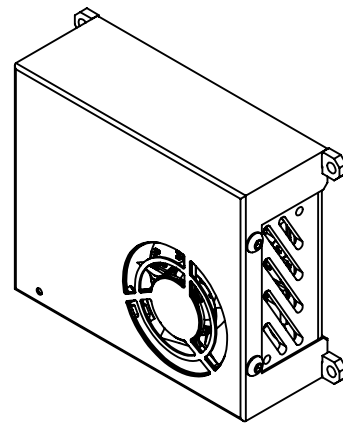
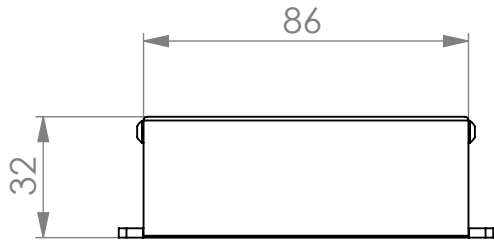

B

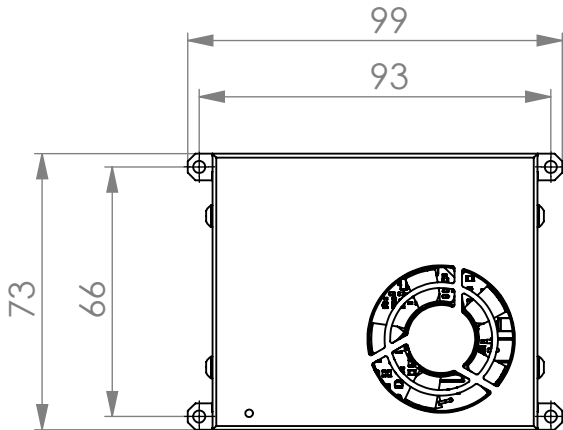

C

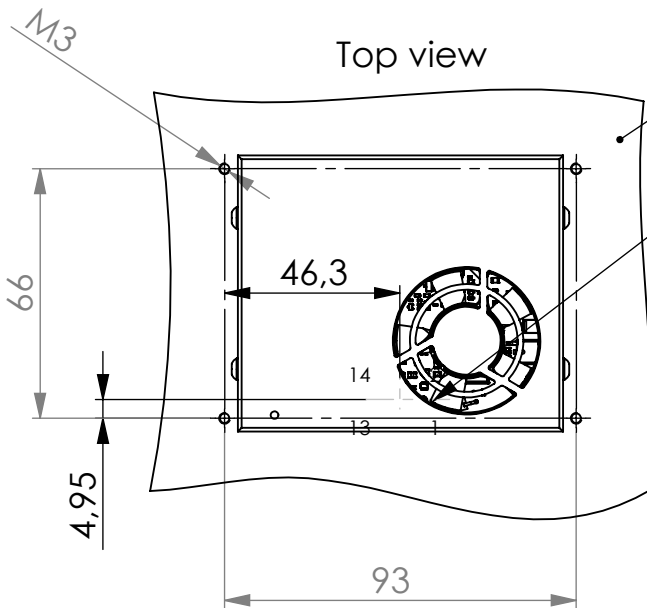

Customer PCB

HLE-107-02-L-DV-TE

- 1: PZT_OUT (-45V..+180V)
- 2: n.c.
- 3: n.c.
- 4: Status
- 5: PZT_GND
- 6: Temp
- 7: GND
- 8: Signal (-3..+12V)
- 9: GND
- 10: Output_Enable
- 11: Supply_GND
- 12: Power_Enable
- 13: Supply +24V (min. 2A)
- 14: Sync

D

E

Tolerierung/Tolerances: ISO 8015 / ISO 2768-f
 Oberflächenangaben/Surface: ISO 1302
 Werkstückkanten/Edge of workpiece: ISO13715
 Zusätzliche Maße sind dem 3D Modell zu entnehmen. Additional dimensions are stated in the 3D model.

Oberfläche / Surface

Maßstab / Scale: 1:2

Gewicht / Weight: 149.68 g



Werkstoff / Material:

Benennung / Title:

EPO-060100

Treiberelektronik für Piezoaktoren, -45..+180

Zeichnungsnummer / Drawing No.:

00000283

Revision

00

Blatt 1

von 1

A4

VORABVERSION

Datum/Date Name

Bearb. 12.05.2023 KPo

Freig.

Schutzvermerk ISO 16016 beachten.
Refer to protection notice ISO 16016.



Rev.	Änderung	Datum	Name

Ursprung:

letzte Speicherung: 15.05.2023

F